

# Pacific Gas and Electric Company

## Residential Pool Program

### Application Assessment Report # 0918

#### Laboratory Testing of Residential Pool Cleaners (San Ramon, CA)

**Issued:** March 2010

**Project Manager:** Oksana Harris  
Pacific Gas and Electric Company

**Program Engineer:** Lianne Williams  
Pacific Gas and Electric Company

**Program Engineer:** Alina Zohrabian  
Pacific Gas and Electric Company

**Prepared By:** Gary Fernstrom, Sr. Program Engineer  
Codes and Standard Program

#### Legal Notice

This report was prepared by Pacific Gas and Electric Company for exclusive use by its employees and agents. Neither Pacific Gas and Electric Company nor any of its employees and agents:

- (1) makes any written or oral warranty, expressed or implied, including, but not limited to those concerning merchantability or fitness for a particular purpose;
- (2) assumes any legal liability or responsibility for the accuracy, completeness, or usefulness of any information, apparatus, product, process, method, or policy contained herein; or
- (3) represents that its use would not infringe any privately owned rights, including, but not limited to, patents, trademarks, or copyrights.

## CONTENTS

List of Appendix: .....	iii
EXECUTIVE SUMMARY .....	1
INTRODUCTION .....	3
Background .....	3
Acknowledgement .....	3
Prior Research .....	3
Objectives .....	3
METHODOLOGY .....	3
Testing Standards .....	3
Test Apparatus .....	4
Power, Measurements, and Instrumentation .....	5
Data Acquisition System .....	6
Test Conditions .....	6
Test Procedure .....	6
RESULTS .....	6
Discussion .....	6
Energy Factor .....	9
Energy Savings .....	10
Annual Cost of Operation .....	11
CONCLUSIONS .....	11
Appendix A: Tested Cleaner Pictures .....	12
Appendix B: Graphs of Cleaner Flow VS Cleaner Pressure and Hydraulic Power .....	21

## LIST OF TABLES

Table 1: Comparative Cleaner Incremental Power Demand & Energy Use* .....	2
Table 2: Test Summary- Booster Pump Required Hydraulic Cleaner Typical Operation .....	8
Table 3: Test Summary- Filtration Pump Pressure Side Hydraulic Cleaner Typical Operation .....	8
Table 4: Test Summary- Filtration Pump Suction Side Hydraulic Cleaner Typical Operation .....	9
Table 5: Test Summary- Robotic Cleaners-Test Duration 10min .....	9
Table 6: Incremental Demand Reduction and Energy Savings .....	10
Table 7: Example of CEC Appliance Database Report of Pump Performance .....	10

## LIST OF FIGURES

Figure 1: Pressure-Side cleaner Plumbing .....	2
Figure 2: Suction-Side cleaner Plumbing .....	2
Figure 3: Pool Trailer Test Setup .....	4
Figure 4: Hydraulic cleaner test setup .....	4
Figure 5: Generator & Robotic Test Measuring Instruments .....	5
Figure 6: Block Diagram of Test Setup Connections .....	5
Figure 7: Hydraulic Measuring Instruments .....	6
Figure 8: Illustration of Hydraulic Sensors .....	6

**LIST OF APPENDIX:**

Appendix: Figure A- Robotic Cleaner-Tiger Shark..... 12

Appendix: Figure B- Robotic Cleaner-Blue Pearl ..... 12

Appendix: Figure C- Robotic Cleaner-Aquabot Turbo-T ..... 12

Appendix: Figure D- Robotic Cleaner-Dolphin Dx3..... 13

Appendix: Figure E- Robotic Cleaner-Aquabot Turbo-Tjet..... 13

Appendix: Figure F- Robotic Cleaner-Nitro Wall Climber ..... 14

Appendix: Figure G- Booster Pump Required Cleaner-Polaris 280..... 14

Appendix: Figure H- Booster Pump Required Cleaner-Polaris 3900 Sport ..... 15

Appendix: Figure I- Booster Pump Required Cleaner- Hayward Phantom..... 15

Appendix: Figure J- Filtration Pump Pressure Side Cleaner-Polaris 360..... 16

Appendix: Figure K- Filtration Pump Pressure Side Cleaner-The Pool Cleaner..... 16

Appendix: Figure L- Filtration Pump Pressure Side Cleaner-Pentair Letro ..... 17

Appendix: Figure M- Filtration Pump Suction Side Cleaner-Polaris ATV ..... 17

Appendix: Figure N- Filtration Pump Suction Side Cleaner-Zodiac G3-Baracuda..... 18

Appendix: Figure O- Filtration Pump Suction Side Cleaner-Deep Sweep ..... 18

Appendix: Figure P- Filtration Pump Suction Side Cleaner-The Pool Cleaner (No Test Picture) ..... 19

Appendix: Figure Q- Filtration Pump Suction Side Cleaner-Hayward King Ray ..... 19

Appendix: Figure R- Filtration Pump Suction Side Cleaner-Hayward Pool VAC Ultra..... 20

Appendix: Figure S- Polaris 280 (Booster Pump Required)-Hydraulic Performance ..... 21

Appendix: Figure T- Polaris 3900 Sport (Booster Pump Required)-Hydraulic Performance ..... 21

Appendix: Figure U- Hayward Phantom (Booster Pump Required)-Hydraulic Performance..... 21

Appendix: Figure V- Polaris 360 (Filtration Pump-Pressure Side)-Hydraulic Performance..... 22

Appendix: Figure W- The Pool Cleaner (Filtration Pump-Pressure Side)-Hydraulic Performance ..... 22

Appendix: Figure X- Pentair Letro (Filtration Pump-Pressure Side)-Hydraulic Performance..... 22

Appendix: Figure Y- Polaris ATV(Filtration Pump-Suction Side)-Hydraulic Performance..... 23

Appendix: Figure Z- Zodiac G3 Baracuda (Filtration Pump-Suction Side)-Hydraulic Performance ..... 23

Appendix: Figure AA- Hayward Pool VAC ULTRA (Filtration Pump-Suction Side)-Hydraulic Performance ..... 23

Appendix: Figure BB- Hayward King Ray (Filtration Pump-Suction Side)-Hydraulic Performance..... 24

Appendix: Figure CC- The Pool Cleaner (Filtration Pump-Suction Side)-Hydraulic Performance..... 24

Appendix: Figure DD- The Deep Sweep (Filtration Pump-Suction Side)-Hydraulic Performance ..... 24

## EXECUTIVE SUMMARY

In an effort to improve the power demand reduction and energy savings opportunity in PG&E's Swimming Pool Pump energy efficiency program, swimming pool cleaners, or sweeps, were tested and evaluated during 2009. Nearly all swimming pool cleaners currently installed are hydraulically powered by the swimming pool filtration pump, or by a separate booster pump connected to the discharge of the filtration pump. There are swimming pool pumping system interactive effects between the pool cleaner and filtration pumping, where maximum efficiency of pool filtration pumping is limited by cleaner operation.

In this report, reference will be made to the non incremental power and energy required and the incremental power and energy required. The non incremental is the actual hydraulic power and energy needed to simply run the cleaner. The incremental power and energy is the additional power and energy needed to run the two speed filtration pump at the higher speed, which is common practice during cleaning. Due to the pump affinity law, the incremental power and energy is much greater than the non incremental power and energy.

In California, where two speed pumps are required for residential filtration applications of one total horsepower or greater, hydraulic cleaners add incrementally to the pool pump power and energy because these pumps are most commonly run on high speed to operate the cleaners.

A relatively new class of robotic, self-powered cleaners operate through a power cord connected to a low voltage power supply plugged into an electrical outlet. This is independent of the pool pump filtration system, and eliminates the need for booster pumps. This measure, when used with two speed or variable speed pumps, allows for more efficient, lower speed operation of filtration pumps, and offers an energy efficiency and demand reduction opportunity.

Since no test procedure or measure of efficiency performance existed for pool cleaners, they had to be developed. The initial approach was to pursue a cleaner energy factor, derived from the area of pool floor covered (square feet) per unit of energy consumed (kWh). This approach was subsequently abandoned, as this simple measure proved to be an inadequate indicator of cleaning performance given the idiosyncrasies of individual cleaners relative to pool plumbing, geometry, in-pool obstructions, and debris load. We decided that no simple measure of cleaning performance could be developed for all pool types, so this factor is best left to the judgment of pool professionals.

The project team believed that robotic cleaners as a class would prove to be significantly more efficient than filtration pump powered hydraulic cleaners, and particularly more efficient than booster pump powered cleaners. This opinion was based on observation and measurements in several pools. Booster pumps were observed to typically draw 1.2 kW. Filtration pump powered cleaners were thought to require greater flow, increased pump speed, and extend pumping time to filter the equivalent volume of water than would be needed if cleaning were provided by an independent robotic cleaner.

Robotic cleaners were found to use an order of magnitude less energy than hydraulic cleaners, when the incremental cleaning related energy use of two speed pump(s) was measured. The robotic cleaner's electrical power demand and energy use proved to be quite similar to the hydraulic cleaner's hydraulic power and energy, but significantly greater incremental input to two speed pump(s) was needed to power them. When hydraulic cleaners are used, the actual system performance is significantly compromised by interactive effects with the pool filtration pump. Pool skimmers and main drains for suction-side cleaners, along with pool returns and other features for filtration pump pressure-side cleaners, share the water flow with the cleaners preventing either from operating at optimum energy efficiency performance.

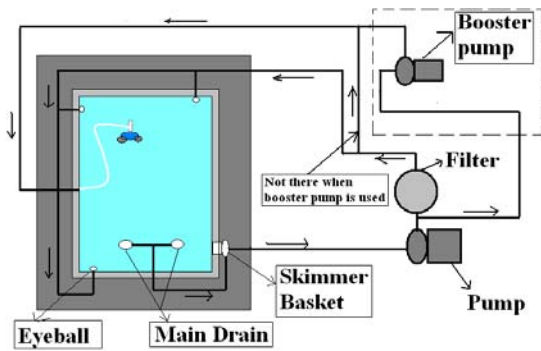

**Figure 1: Pressure-Side cleaner Plumbing**

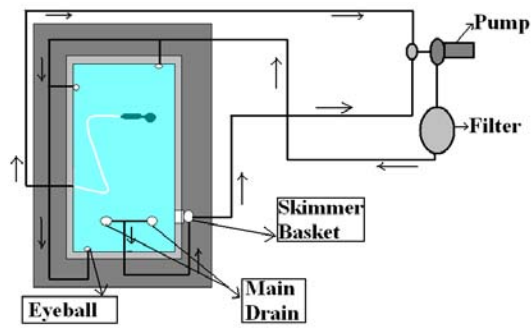

**Figure 2: Suction-Side cleaner Plumbing**

\* Suction-side cleaners can alternatively be plumbed into the skimmer basket

For example, skimmers and main drains require a minimum of 25 to 30 GPM of suction side flow to operate properly. Pool return, directive “eyeballs” require similar flow and have a similar effect on the discharge side of the filtration pump. Since pools do not have motor operated valves to operate pool circulation and cleaning sequentially, hydraulic cleaners add to these minimum flows during the time they operate. To meet the increased flow requirement, two speed pumps are normally operated at high speed, roughly doubling the flow, based on the affinity law. According to the pump affinity law, speed is proportional to flow, pump power increases as the cube of the flow, and energy as the square of the flow, causing the cleaner’s incremental “interactive” effect to come at a high “incremental” power and energy cost. This power cost is 8 times greater and the incremental energy cost is 4 times greater than if the cleaner function operated separately or sequentially.

Booster pump required cleaners are typically overpowered by ¾ HP, 1.5 Service Factor, standard efficiency pumps drawing 1.2 kW, despite the cleaner’s relatively low hydraulic power requirement. Further, booster pump suction is typically connected to the filtration pump’s discharge, so it is common practice to have filtration pumps operating at full speed whenever booster pumps are running. The composite effect is that the lowest filtration flow and speed is doubled (drawing 8 times the slow speed power) to additionally serve the booster pump, which in turn draws 1.2 kW.

In this report cleaners were assumed to operate 3 hours per day to be consistent with the typical robotic cleaner operation. This allowed for a better comparison between Robotic and Hydraulic cleaners. The 2009 PG&E KEMA study shows an average cleaner operation of 2.55 hours for booster pump required cleaners.

**Table 1: Comparative Cleaner Incremental Power Demand & Energy Use\***

Cleaner Type	Cleaner Hydraulic Input Power (HP)	Cleaner Hydraulic Input Power (kW)	Motor Mechanical Rated Power** (HP) / (THP)	Incremental Motor Electrical Input Power** (kW)	Hours of Cleaner Operation	Daily Energy Use (kWh)	Annual Energy Use*** (kWh)
Robotic	N/A	N/A	N/A	0.180	3	0.54	197
Filtration Pump (Suction-side) cleaner	0.02	0.015	2.0 / 2.6	1.53	3	4.59	1675
Filtration Pump (Discharge-side) cleaner	0.09	0.067	2.0 / 2.6	1.53	3	4.59	1675
Booster Pump Required Cleaner	0.07	0.052	3/4 / 1-1/8	1.53 (filtration)**** + 1.2 (booster)	3	8.19	2989

\* The annual Energy use and Demand in this table is based on having a CA Title 20 required two speed filtration pump. Results for variable and single speed pumps will vary.

\*\*Assumes cleaner power is incremental and represents marginal values using CEC Appliance Database pump (sta-Rite-P6RA6YG-207L)

\*\*\* Assumes cleaner runs 365 day per year

\*\*\*\* Filtration pump runs on high speed when booster pump is running

## INTRODUCTION

### Background

PG&E looked at opportunities to broaden the scope of its swimming pool pump program. This included investigating additional pool related measures which would add savings to the program as well as improve filtration pump related savings by allowing lower filtration pump flow and speed, which translates to lower energy use. Good opportunities identified included automatic pool cleaners, or sweeps, backwash valves, underwater lighting, and solar thermal heating system pumping. Of these opportunities, a project was initiated to investigate automatic swimming pool cleaners, or sweeps. Since no test procedure or energy efficiency performance data existed, a test procedure had to be developed. Products then needed to be obtained and tested to determine base case energy use and potential savings.

### Acknowledgement

Testing was facilitated by the generous donation of 18 pool cleaners by 7 manufacturers. Without these products and related technical assistance, the testing would not have been possible. The project team appreciates this generosity and support for energy efficiency improvement.

### Prior Research

To the best of the author's knowledge, no one has previously developed a test procedure for determining pool cleaner energy efficiency performance, nor has anyone evaluated such performance.

### Objectives

The objective of the pool cleaner testing was to determine the power demand and energy usage of the different types of pool cleaners; i.e. robotic self-powered, hydraulic booster pump powered, and hydraulic pressure or suction side filtration pump powered. The project specifically intended to:

- Consider eligible product categories for the potential development of program measure expansion
- Identify the most efficient pool cleaner types
- Determine potential energy savings of more efficient pool cleaners relative to a base case
- Discover and evaluate other related factors, such as the effect that pool cleaners have on the overall pool operation and energy use

## METHODOLOGY

### Testing Standards

There are no existing test procedures for determining swimming pool cleaner energy efficiency performance. Therefore, the project team needed to develop a test procedure.

Assessing cleaners on the basis of energy efficiency alone, in the absence of any measure of cleaning effectiveness, did not seem like a rational performance measure, so a test procedure was developed that attempted to measure energy use as a function of pool floor area covered. The term "energy factor" was adopted and defined as Watt-hours of energy consumed per square foot of pool floor area cleaned. The test protocol was intended to determine this figure of merit for each category of cleaner tested.

For the robotic cleaners, the electrical power and energy were measured directly. For the hydraulic cleaners, flow and pressure were measured, the water power was calculated, then this was converted to pump brake HP and electrical power using assumed efficiencies of 0.60 for the pump head and 0.75 for the motor. This conversion was not direct, but was incremental or marginal with respect to pump motor power and energy. Since for two speed filtration pumps, cleaner flow and power is additive to other pool needs, such as skimmer, main drain, or direct return flows, it is similarly additive to pump power. The pump affinity law finds pump power directly proportional to the cube of the flow, and energy directly proportional to the square of the flow, so the marginal effects of adding the cleaner are not linear with respect to increased energy use.

### Test Apparatus

With the performance measurement objective selected, a test apparatus needed to be assembled that allowed the linear distance traveled as well as power demanded to be measured. The energy consumed over the test period could then be calculated.

A test stand was built which allowed the measurement and calculation of simulated pool floor area covered by the cleaner per unit of time. The test table was constructed with a rotating drum protruding through the top, such that cleaners could be situated on top of the table while the cleaner wheels rotated the drum. A revolution counter was attached to the drum, such that revolutions could be measured and linear distance and area covered could be calculated. The whole apparatus, cleaner, drum, and table were submerged in a 300 gallon tank for the measurement. (See Figure-3)

This apparatus worked well for robotic cleaners with powered wheels that could turn the drum. A different approach was needed for water jet driven robotic cleaners and for non-wheel-driven hydraulic cleaners. For these cleaners, a test set-up was constructed using a Pentair IntelliFlo VS pump equipped with suction, discharge, cleaner inlet pressure, and system flow meters. From these measurements, water power was calculated, and pump brake HP and electrical HP were calculated using assumed pump head efficiencies of 0.6 and motor efficiencies of 0.75. Calculated values were then adjusted to reflect the incremental increase in pumping power and energy. (See Figure-4)

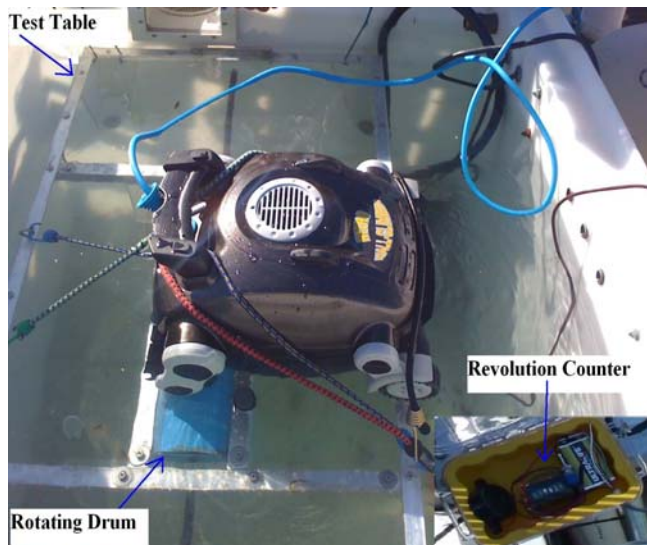

Figure 3: Pool Trailer Test Setup



Figure 4: Hydraulic cleaner test setup

As testing proceeded, it became apparent that developing an energy factor for each cleaner would be difficult, as some cleaners had unpowered wheels, making it impossible for them to turn the drum, and many cleaners had no wheels at all. Further, the cleaning performance of various cleaners in a typical pool was dependent



on factors other than the pool floor area covered, such as ease of set-up for optimum performance, cleaning effectiveness, ability to deal with different sizes of debris, and propensity to get stuck in a particular place due to pool geometry or plumbing fixtures, such as drain covers and steps. While floor area covered and energy factor were determined for robotic cleaners where feasible, this approach was abandoned later as an overly simplistic measure of cleaning performance. Wide variations in cleaning performance were observed. These were highly dependent on pool plumbing, geometry and debris load. In the end, the project team decided to leave performance to professional judgment and evaluate only the energy use.

**Power, Measurements, and Instrumentation**

**System Power**

Electrical power was provided by a GFCI protected Honda 4.5 kW generator, while power for the Pentair IntelliFlo VS pump was provided from the grid through a GFCI protected 120/240 VAC, 4 wire, 20 Amp outlet. (See Figure-5).

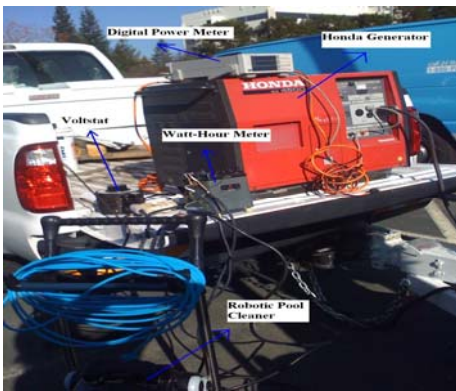

**Figure 5: Generator & Robotic Test Measuring Instruments**

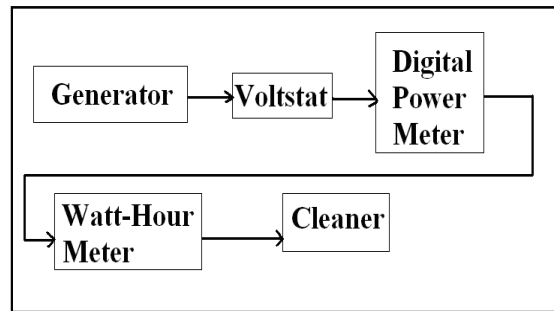

**Figure 6: Block Diagram of Test Setup Connections**

**Electrical Measuring Instrumentation**

Electrical power was supplied through a Matsushita Communications Industrial “Voltstat”, Model VQ 17510 variable voltage transformer, to assure measurement at 120 VAC, ± 0.5 Volts. Voltage and power readings were taken with a Yokogawa WT-110 True RMS Digital Power Meter. Energy measurements were taken in 10 minute intervals with a General Electric Type IB-10 Portable Watt-Hour Meter Standard, set to the 120 Volt, 5 Amp range. (See Figure 5)

**Hydraulic Measuring Instrumentation**

Water flow was provided by a Pentair Intelliflo VS, variable speed pump. Flow was measured by a G F Signet 51530-P0 paddlewheel flow sensor in a 1-1/4 inch Signet F08T012F measurement pipe section and displayed by a Red Lion Controls Model APLR digital rate display. Pressures were measured with Wika Instruments Model N-10, -30 In Hg to +30 psi pressure transmitters, and displayed by Wika tronic, Model 907.50.910 programmable meters, manufactured by Red Lion Controls (See Figure 7 & 8). Back up measurements were made with Wika liquid filled pressure gauges plumbed in parallel with the electronic pressure transducers.



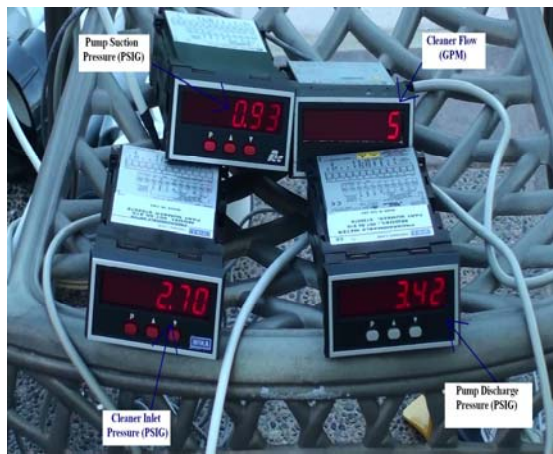

**Figure 7: Hydraulic Measuring Instruments**

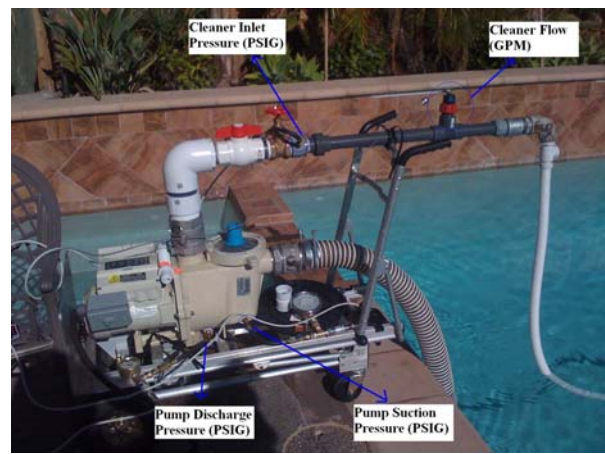

**Figure 8: Illustration of Hydraulic Sensors**

## Data Acquisition System

Since the data acquisition for this project was simple relative to the set-up process for robotic and hydraulic cleaners, no automated data acquisition system was utilized. Measurements were simply recorded as the test parameters were changed.

## Test Conditions

During robotic cleaner testing, voltage was adjusted and maintained at 120 VAC,  $\pm 0.5$  VAC, while voltage, power, and energy use were measured. During hydraulic cleaner testing, flows were set and maintained at values appropriate for minimum, typical, and maximum cleaner operation, while pressures were measured.

## Test Procedure

Robotic cleaners were located on the test stand such that the wheels rotated the drum, but cleared the stationary portion of the table. The test stand and cleaner were then submerged in the 300 gallon tank. Electrical voltage, power, and energy measurements were taken over a 10 minute interval, along with cleaner suction port width and a count of drum rotations.

Hydraulic cleaners were connected to the Pentair IntelliFlo VS pump with approximately 25 feet of hose and were submerged in a 14,000 gallon swimming pool. Pump speed was adjusted while flow and pressure measurements were taken and cleaner operation was observed.

## RESULTS

### Discussion

As expected, robotic cleaners as a class were found to demand the least electrical power and use the least energy of any of the products tested, when installed in pools with two speed filtration pumps, or with systems with booster pumps. They also provide excellent cleaning performance. Average power demand for the class tested was 0.18 kW. We assumed 3 hours of daily operation, for an average daily energy use of 0.54 kWh.

Filtration pump powered hydraulic cleaners worked at a lower flow and demanded less hydraulic power and energy than expected. Non-incrementally, they were similar to the robotic cleaner energy efficiency performance. While the hydraulic cleaners individually were nearly as efficient as the robotic ones, their

actual incremental system performance depends on the pool hydraulic system to which they are connected. Since water flow through the cleaner is shared in these systems with skimmers and main drains in the case of filtration pump powered suction cleaners (see Figure 2), or with pool returns and other features (such as: laminars, etc.) in filtration pump powered pressure cleaners (see Figure 1), actual pump flow, power, and energy use is incrementally additive to the minimum filtration flow needs.

The booster pump required cleaners individually needed less hydraulic power and energy than expected. They were generally similar in overall performance to the other classes of cleaners. This was not expected, as these cleaners are typically powered by a separate  $\frac{3}{4}$  HP nameplate, 1.5 Service Factor, 1.125 Total Horsepower, standard efficiency booster pump, demanding 1.2 kW, indicating that these cleaners could be designed and operated with a much smaller booster pump than normally used. Further, each of these cleaners typically operate at 4 to 8 GPM of flow, suggesting that filtration pumps do not need to operate a full speed and flow to prevent booster pumps from being “starved” for water.

The testing and determination of pool cleaner hydraulic power and energy requirements indicates that there is not a significant difference in the non-incremental energy efficiency performance of the different classes of cleaners; however, in practice and due to the application, there are very significant differences in the pool cleaner system power and energy use requirements. Simply stated:

- Filtration pump powered and booster pump powered hydraulic cleaners, as well as robotic cleaners, have wide variations in cleaning performance depending on their ability to deal with pool plumbing, geometry, in-pool plumbing fixtures, sizes and types of debris.
- All cleaner categories tested in this project have similar non-incremental power requirements, where the power comparison is made between robotic cleaners’ electrical power and hydraulic cleaners’ hydraulic power.
- Filtration pump powered hydraulic cleaners have lower system energy efficiency because their water supply is shared with other pool functions, making it more challenging to optimize filtration pumping for maximum efficiency, and requiring that cleaner flow be supplied incrementally at exponential cost increase in power and energy.
- Booster pump powered cleaners are generally powered with massively oversized,  $\frac{3}{4}$  HP nameplate, 1.5 Service Factor standard efficiency pumps. Since booster pumps are typically connected to filtration pump’s discharge, filtration pumps operate at full speed whenever booster pumps are running, making it unlikely for filtration pumps to run a larger percentage of the time on low speed.

In conclusion, the test results show that for pools with two speed filtration pumps, pool cleaner power demand and energy use can be reduced using a robotic cleaner while operating the pool pump at low flow and speed, for optimum filtration efficiency. Alternatively, improvements for hydraulic cleaners can be made by installing motor operated valves to separate the cleaning and the pool filtration functions, allowing each to be operated sequentially by variable speed pumps for optimum efficiency. Lastly, booster pump cleaner performance can be improved by better sizing of the pump relative to the cleaner hydraulic power demand and by utilizing high efficiency booster pump motors.

Given the complexity and cost of setting up hydraulic cleaners to operate at maximum efficiency, and the relative simplicity of adding a robotic cleaner while operating the pool pump for maximum filtration efficiency, it is recommended that consideration be given to the class of robotic cleaners, with selection for maximum cleaning performance in individual pools left to pool professionals.

Table 2, below, shows the data for booster pump required cleaner’s typical operation. Pressure requirements are higher than those normally produced by pool filtration pumps, indicating the need for dedicated booster pumps. Required flows however, are low, indicating that it may not be necessary to follow the common practice of running filtration pumps at full speed to supply booster pumps. Also, the actual booster pump power requirement is much smaller than the  $\frac{3}{4}$  HP, 1.5 SF pump normally used.

**Table 2: Test Summary- Booster Pump Required Hydraulic Cleaner Typical Operation**

<b>Cleaner Model</b>	<b>Flow (GPM)</b>	<b>Cleaner Inlet Pressure (PSIG)</b>	<b>Hydraulic Horsepower (HP)</b>	<b>Pump Brake Horsepower (HP)</b>	<b>Non Incremental Motor Electrical Power (kW)</b>	<b>Incremental Motor Electrical Power (kW)</b>
<b>Cleaner A</b>	7.33	22.15	0.11	0.18	0.18	1.53 (filtration) + 1.2 (booster)
<b>Cleaner B</b>	7.75	13.92	0.07	0.12	0.12	1.53 (filtration) + 1.2 (booster)
<b>Cleaner C</b>	4.00	16.51	0.04	0.07	0.07	1.53 (filtration) + 1.2 (booster)

Table 3, below shows the data for filtration pump powered pressure side cleaners typical operation. While the flows and pressures vary for the different cleaners in this class the hydraulic horsepower required by these cleaners is similar. If operated independently, the pump motor power requirement for the cleaner would be low, but these cleaners are normally operated in parallel with pool returns, such as directional “eyeballs”, laminars, and other water features. Adding the cleaner and other features to minimum filtration flows moves the operating point of the pump up the pool hydraulic system curve. This typically requires full speed, in lieu of low-speed, operation in two-speed filtration pumping systems. Pump affinity laws show that doubling the flow and speed of the filtration pump to serve cleaners, requires 8 times the filtration flow power and 4 times the energy for the 3 hour typical cleaner operating time.

**Table 3: Test Summary- Filtration Pump Pressure Side Hydraulic Cleaner Typical Operation**

<b>Cleaner Model</b>	<b>Flow (GPM)</b>	<b>Cleaner Inlet Pressure (PSIG)</b>	<b>Hydraulic Horsepower (HP)</b>	<b>Pump Brake Horsepower (HP)</b>	<b>Non Incremental Motor Electrical Power (kW)</b>	<b>Incremental Motor Electrical Power (kW)</b>
<b>Cleaner D</b>	15.00	8.00	0.08	0.13	0.13	1.53
<b>Cleaner E</b>	27.50	4.88	0.10	0.16	0.16	1.53
<b>Cleaner F</b>	12.50	9.72	0.09	0.15	0.15	1.53

Table 4, below, shows the data for filtration pump powered suction side cleaners typical operation. As in the case of filtration pump powered pressure side cleaners, the cleaner hydraulic and motor power requirements are small. However when added incrementally to main drain, and skimmer flow requirements, two speed filtration pumps are forced from low to high speed operation, doubling the flow and speed of the filtration pump, requiring 8 times the filtration flow power and 4 times the energy for the 3 hour typical cleaner operating time.

**Table 4: Test Summary- Filtration Pump Suction Side Hydraulic Cleaner Typical Operation**

<b>Cleaner Model</b>	<b>Flow (GPM)</b>	<b>Pump Suction Pressure (PSIG)</b>	<b>Hydraulic Horsepower (HP)</b>	<b>Pump Brake Horsepower (HP)</b>	<b>Non Incremental Motor Electrical Power (kW)</b>	<b>Incremental Motor Electrical Power (kW)</b>
<b>Cleaner G</b>	22.50	1.46	0.02	0.03	0.03	1.53
<b>Cleaner H</b>	20.00	1.87	0.02	0.04	0.04	1.53
<b>Cleaner I</b>	17.50	0.77	0.01	0.02	0.02	1.53
<b>Cleaner J</b>	18.29	1.59	0.02	0.03	0.03	1.53
<b>Cleaner K</b>	22.50	0.90	0.01	0.02	0.02	1.53
<b>Cleaner L</b>	32.50	1.84	0.04	0.06	0.06	1.53

Table 5, below, shows the data for robotic cleaners. Among these cleaners, the energy factor varies by a ratio of more than 3 to 1, indicating that some robotic cleaners cover significantly more pool bottom surface area per unit of energy consumed than others, but as noted elsewhere in this report, energy factor was not considered an adequate measure of overall cleaning performance.

Robotic cleaners are the most energy efficient automatic cleaning option, as they draw an average of 0.180 kW, do not require a separate booster pump drawing 1.2 kW, and do not add incrementally to filtration pump power demand and energy use in any non-linear, exponential way.

**Table 5: Test Summary- Robotic Cleaners-Test Duration 10min**

<b>Cleaner Model</b>	<b>Cleaner Suction Width (in)</b>	<b>Number of Revolutions per 10 Minutes</b>	<b>Linear Distance Traveled (feet)</b>	<b>Average Power Demand (kW)</b>	<b>Linear Velocity (ft/min)</b>	<b>Energy Factor (sf/watt-hr)</b>
<b>Cleaner M</b>	12.75	305	479	0.19	47.91	15.96
<b>Cleaner N</b>	12.50	253	397	0.20	39.74	12.67
<b>Cleaner O</b>	12	170	267	0.18	26.70	8.96
<b>Cleaner P</b>	12.75	544	855	0.15	85.45	35.79
<b>Cleaner Q</b>	12	278	437	0.06	43.67	41.51
<b>Cleaner R</b>	NA	0	0	0.30	0.00	0.00

### Energy Factor

While a good concept, energy factor was eventually abandoned due to difficulty in fairly characterizing pool cleaner cleaning performance, and normalizing the results for this performance. Cleaning performance is pool specific and best left to the judgment of pool professionals.

## Energy Savings

Energy savings and demand reduction calculations are based on Title 20 required two speed filtration pump(s) and field observation that for the 3 hours of typical operation, hydraulic cleaners add to the filtration system flow requirements. While filtration could proceed at 30 GPM (for example), to achieve satisfactory cleaner operation, it is common practice to run the filtration pump on high speed, increasing flow by 30 GPM for the duration of cleaning.

In the case of filtration pump powered hydraulic suction and discharge side cleaners, the pump affinity law defines the additional, incremental power needed to supply this additional cleaner flow. As the flow doubles to accommodate the cleaner needs, the power demand increases by a factor of 8 and the energy use by a factor of 4.

This additional use minus the energy use of the robotic cleaner represents the savings that could be realized if filtration pumps are run at optimal speeds for filtration, and robotic cleaners are used to accommodate the pool cleaning needs.

For booster pump powered cleaners, the additional energy use is that calculated by multiplying the power demanded by the booster pump by the amount of time it operates. The energy savings that could be realized is this value minus the energy use of the robotic cleaner. It is common practice to run the filtration pump at full speed while the booster pump is operating, compounding the savings opportunity. The increased power needed to run the filtration pump at full speed was 1.53kW. (See Table 6)

**Table 6: Incremental Demand Reduction and Energy Savings**

Cleaner Type	Base Case Demand (kW)	Measure Case Demand (kW)	Net Demand Savings (kW)	Typical Hrs of Operation	Annual Energy Savings (kWh)
Robotic	N/A	0.18	0	3	Base Case – N/A
Filtration Pump (Suction-side) Cleaner	1.53	0.18	1.35	3	1478
Filtration Pump (Discharge-side) Cleaner	1.53	0.18	1.35	3	1478
Booster Pump Required Cleaner	1.2 ( <i>booster</i> ) +1.53 ( <i>filtration</i> )	0.18	2.55	3	2792

Demand reduction and energy savings calculations are done using data reported by manufacturers to the California Energy Commission's Appliance Database. This calculation is made with a two speed Sta-Rite pump using a capacitor start, capacitor run motor. Motor nameplate horsepower is 2, with a Service Factor of 1.1, for a Total motor Horsepower of 2.2. (See Table 7)

**Table 7: Example of CEC Appliance Database Report of Pump Performance**

Model Name	Motor Efficiency %	Nameplate HP	Curve-A gpm Flow	Curve-A Power Watts	Curve-A Energy Factor
P6RA6YG-207L (HIGH SPEED)	76	2.0	63	1941	1.95
P6RA6YG-207L (LOW SPEED)	48	2.0	35	415	5.06

## Annual Cost of Operation

The average demand for robotic cleaner is 0.18 kW. The recommended operation of the robotic cleaners vary from 1-3 hrs depending on the model. In the calculations below, a conservative operation time of 3 hrs is used. Also, \$0.30/kWh is used because this is a typical marginal rate for residential pool owners.

The annual cost of operation of robotic cleaners is then  $0.180 \text{ kW} * 3 \text{ hours per day} * 365 \text{ days per year} * \$0.30 \text{ per kWh}$ . This cost is \$59/yr.

The annual cost of operation for booster pump powered hydraulic cleaners is then demand of  $(1.2+1.53) \text{ kW} * 3 \text{ hours per day} * 365 \text{ days per year} * \$0.30 \text{ per kWh}$ . This cost is \$897/yr.

The annual cost of operation of pool filtration pump powered cleaners is a little more difficult to determine due to the interactive effects of filtration and cleaning pumping needs. Filtration would ideally be accomplished on the low speed of a Title 20 compliant 2-speed filtration pump, but adding the additional flow needs of the cleaner is normally accommodated by operating the filtration pump on high speed. Therefore, the annual cost of operation of filtration pump powered cleaners is the cost per kWh times the high speed demand minus the low speed demand, times 3 hours, times 365 days per year, or  $\$0.30/\text{kWh} * (1.941 \text{ kW} - 0.415 \text{ kW}) * 3 \text{ hours/day} * 365 \text{ days/year} = \$501/\text{yr}$ .

## CONCLUSIONS

Robotic cleaners demand less power than needed by filtration pumps and motors that supply hydraulic cleaners in addition to basic filtration needs. They offer an energy saving and demand reduction opportunity.

As shown in Table 6, estimated incremental power demand reduction and annual energy savings by replacing the following cleaners with a robotic cleaner are:

- 1.35 kW and 1,478 kWh for two speed filtration pump powered discharge (pressure) side and suction side cleaners as a baseline
- 2.55 kW and 2,792 kWh for booster pump powered cleaners as a baseline with a two speed filtration pump

**APPENDIX A: TESTED CLEANER PICTURES**

**Appendix: Figure A- Robotic Cleaner-Tiger Shark**

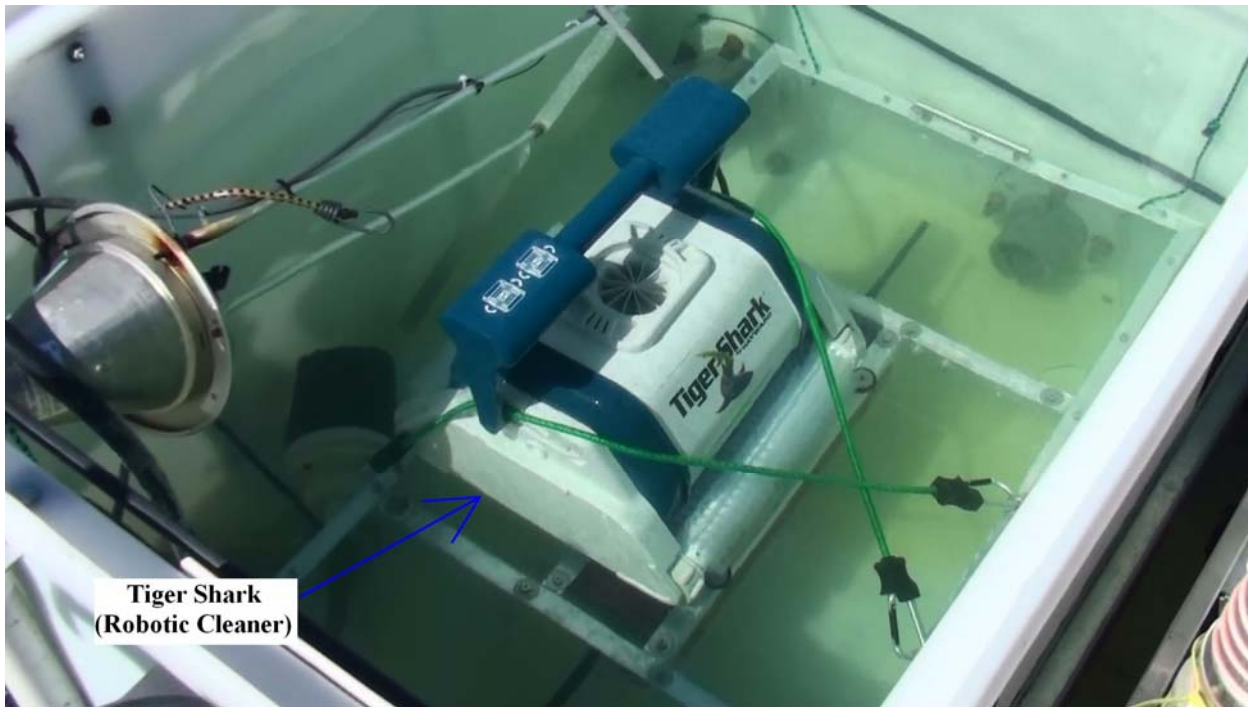

**Appendix: Figure B- Robotic Cleaner-Blue Pearl**

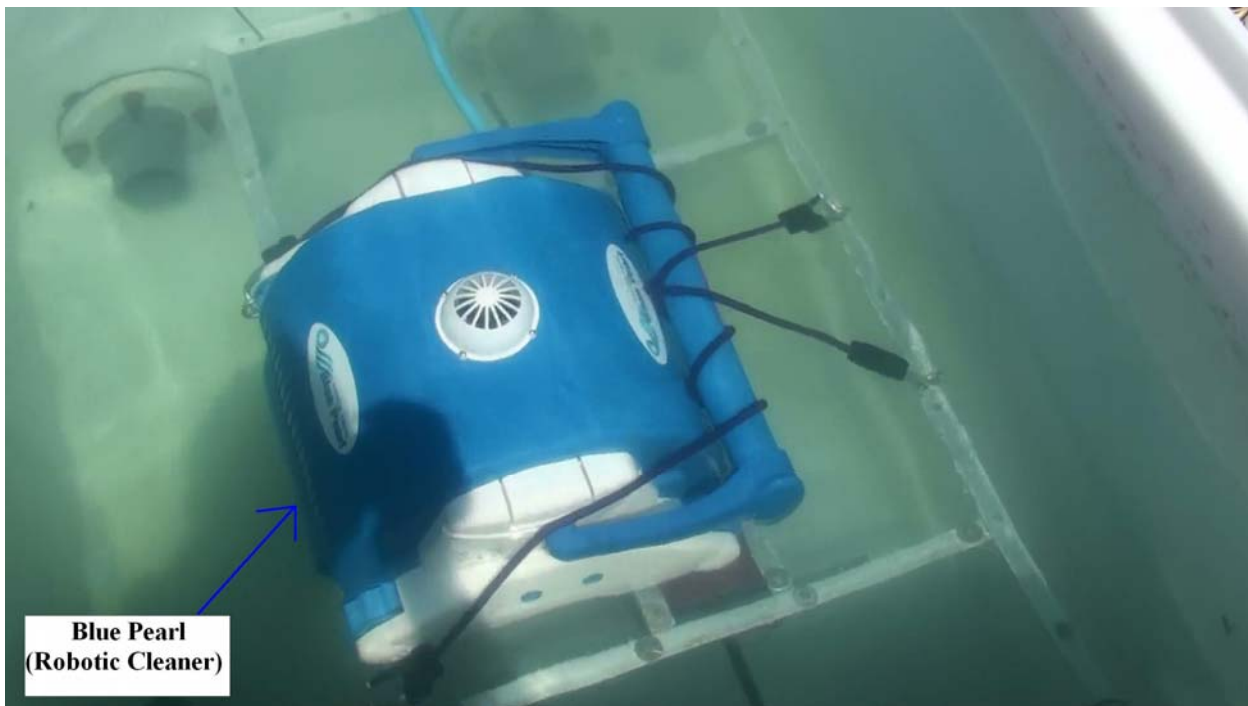

**Appendix: Figure C- Robotic Cleaner-Aquabot Turbo-T**





**Aquabot Turbo-T  
(Robotic Cleaner)**

**Appendix: Figure D- Robotic Cleaner-Dolphin Dx3**

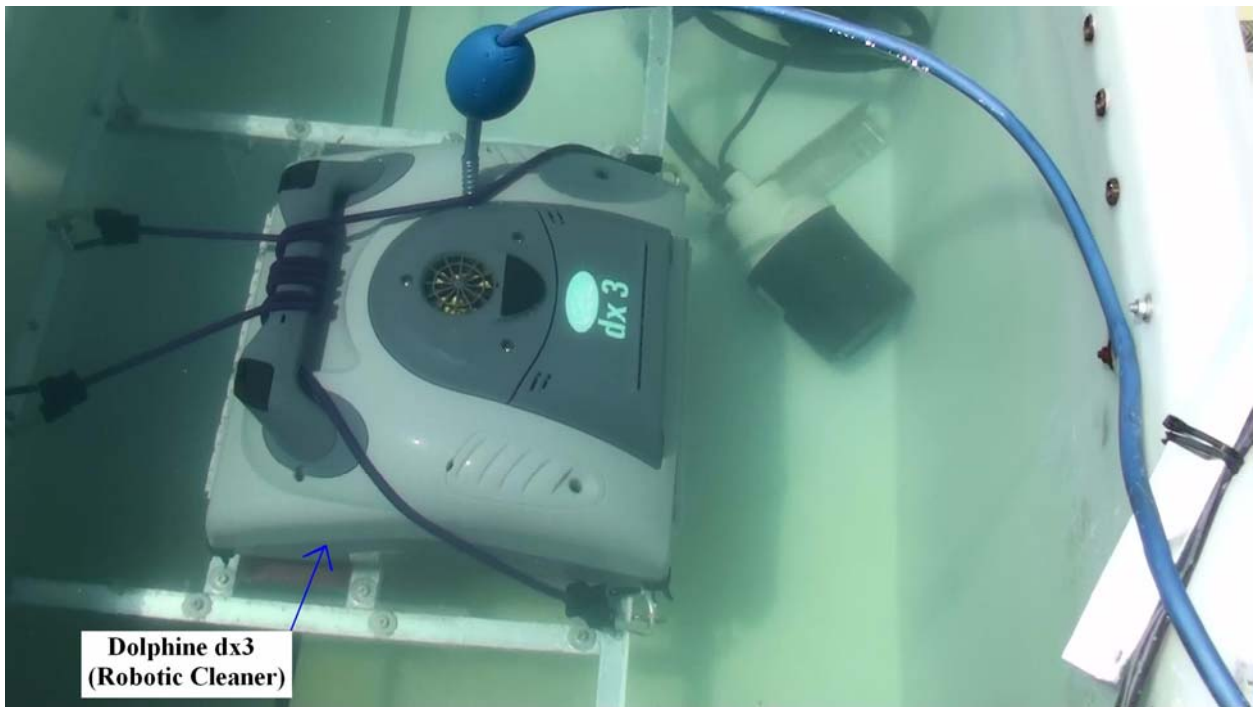

**Dolphine dx3  
(Robotic Cleaner)**

**Appendix: Figure E- Robotic Cleaner-Aquabot Turbo-Tjet**

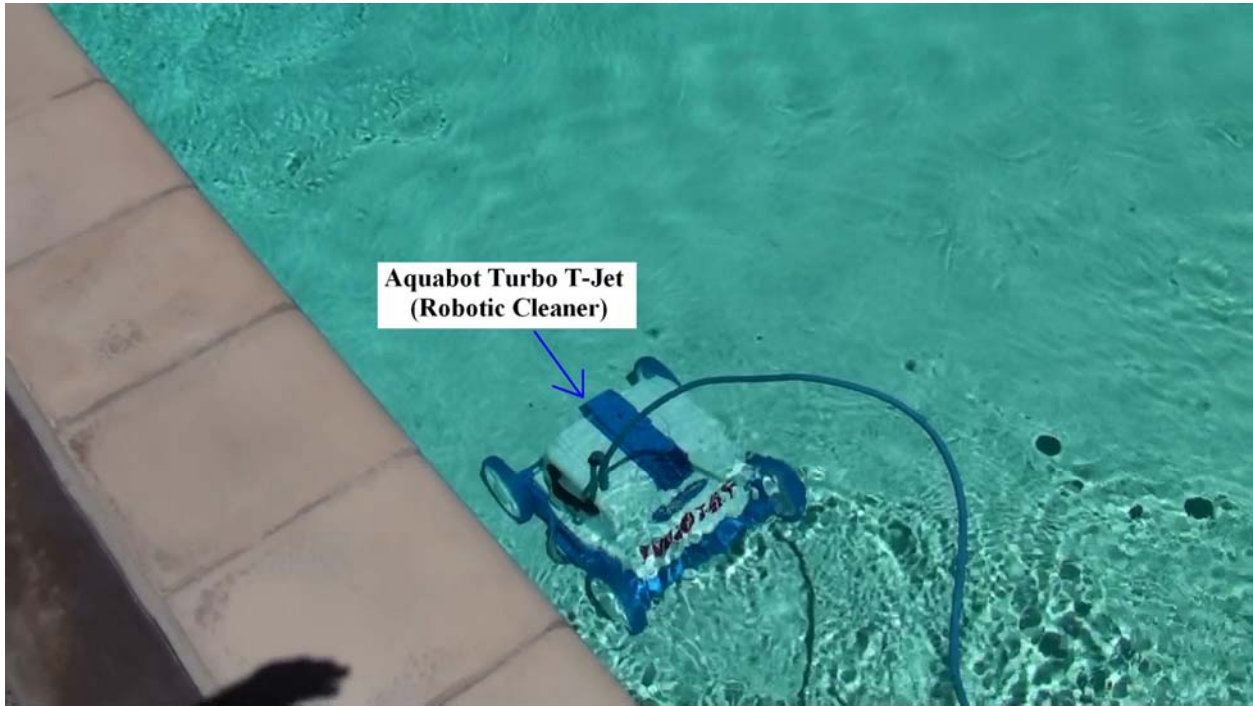

**Aquabot Turbo T-Jet  
(Robotic Cleaner)**

**Appendix: Figure F- Robotic Cleaner-Nitro Wall Climber**

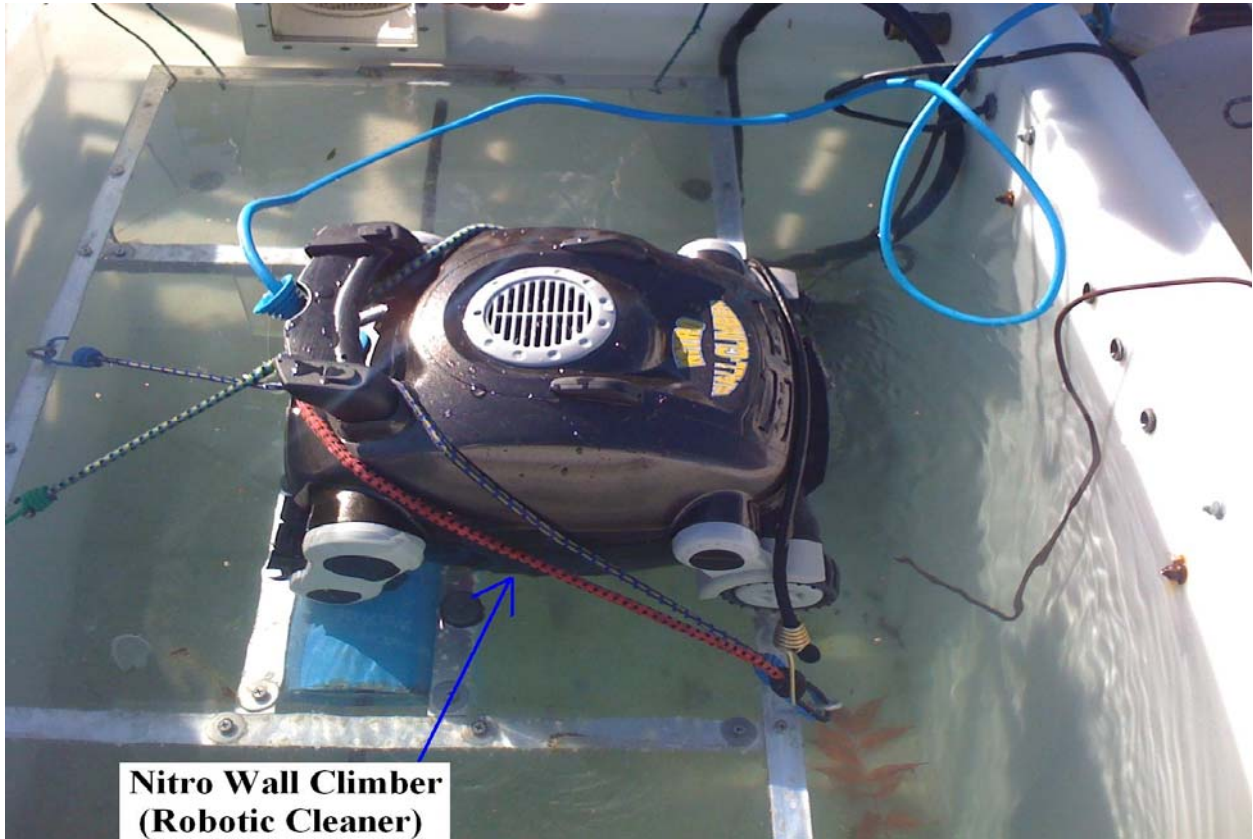

**Nitro Wall Climber  
(Robotic Cleaner)**

**Appendix: Figure G- Booster Pump Required Cleaner-Polaris 280**

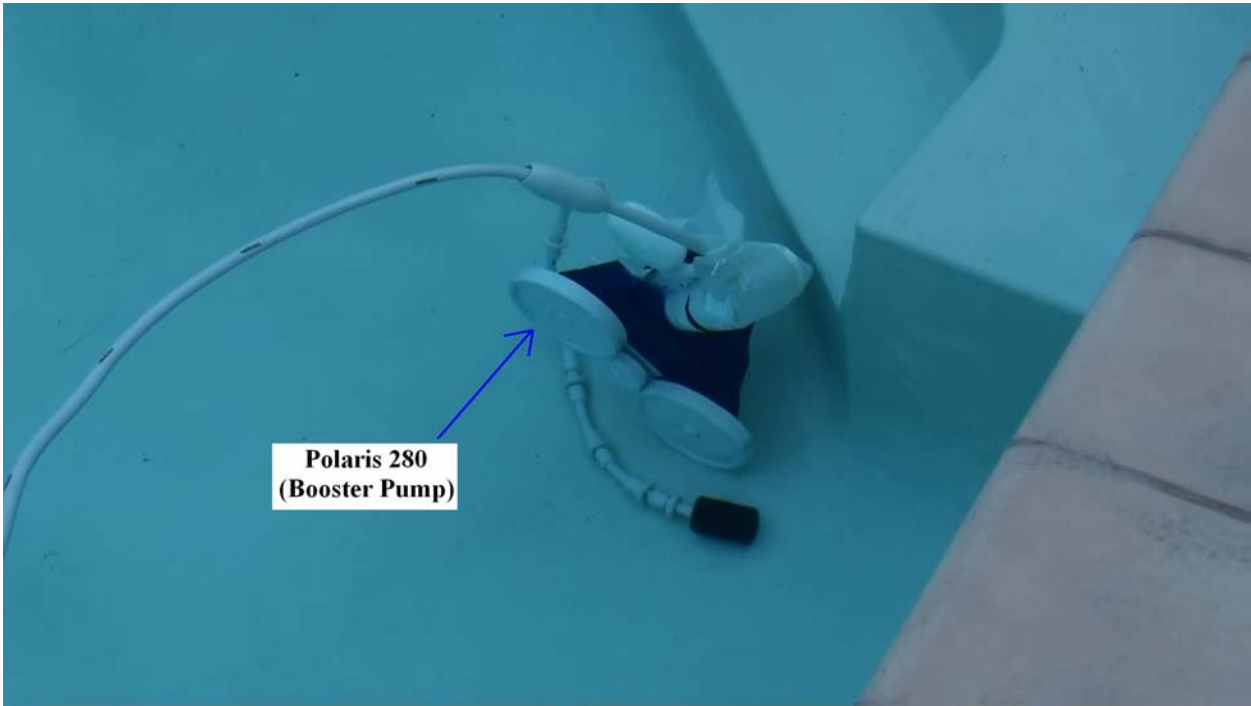

**Appendix: Figure H- Booster Pump Required Cleaner-Polaris 3900 Sport**

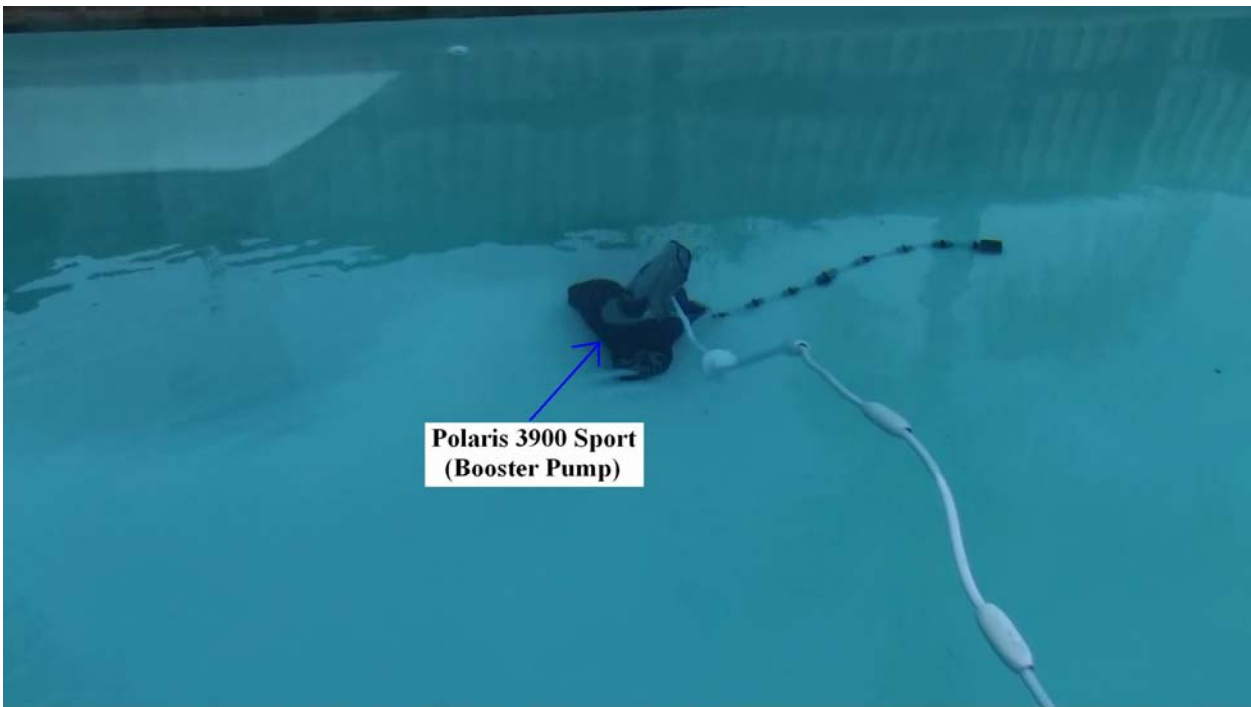

**Appendix: Figure I- Booster Pump Required Cleaner- Hayward Phantom**



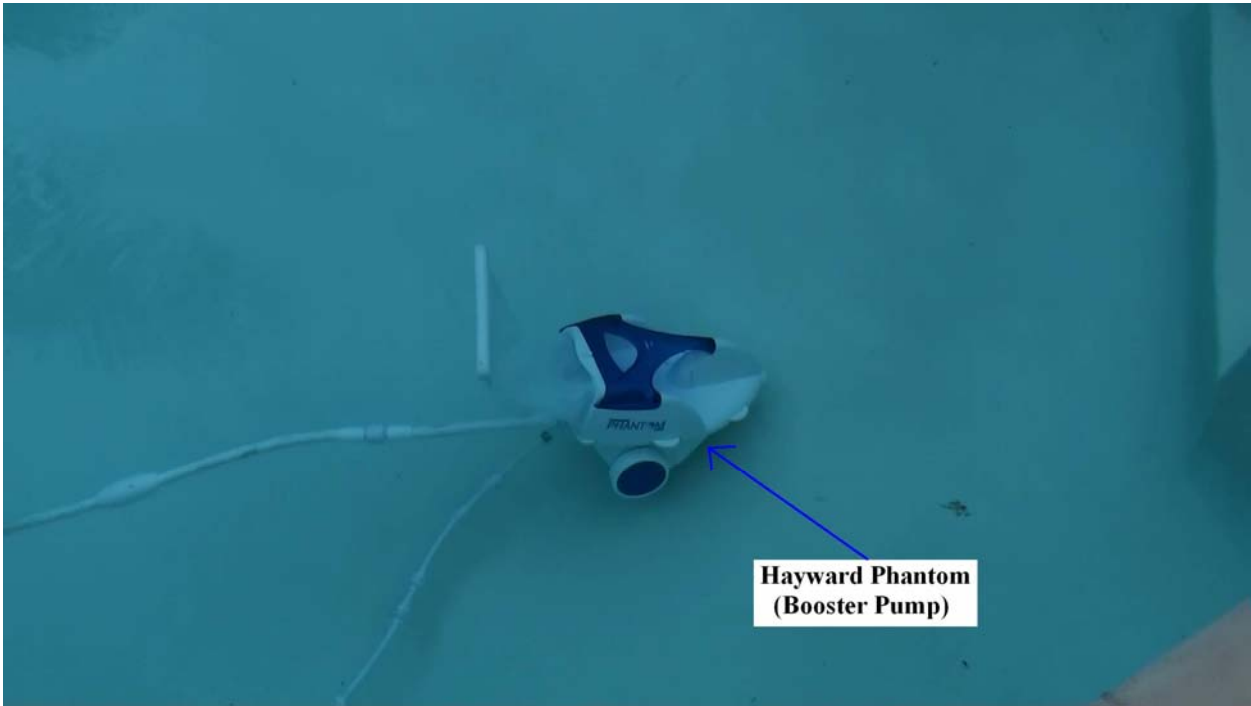

**Appendix: Figure J- Filtration Pump Pressure Side Cleaner-Polaris 360**

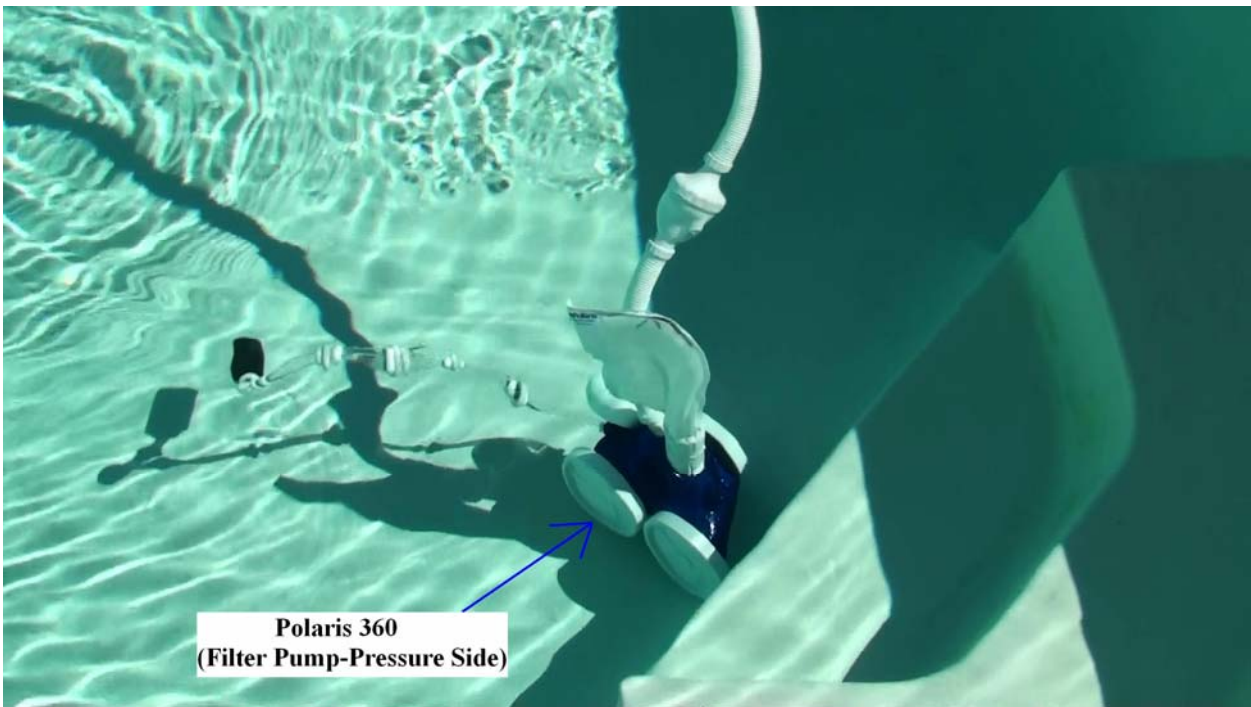

**Appendix: Figure K- Filtration Pump Pressure Side Cleaner-The Pool Cleaner**

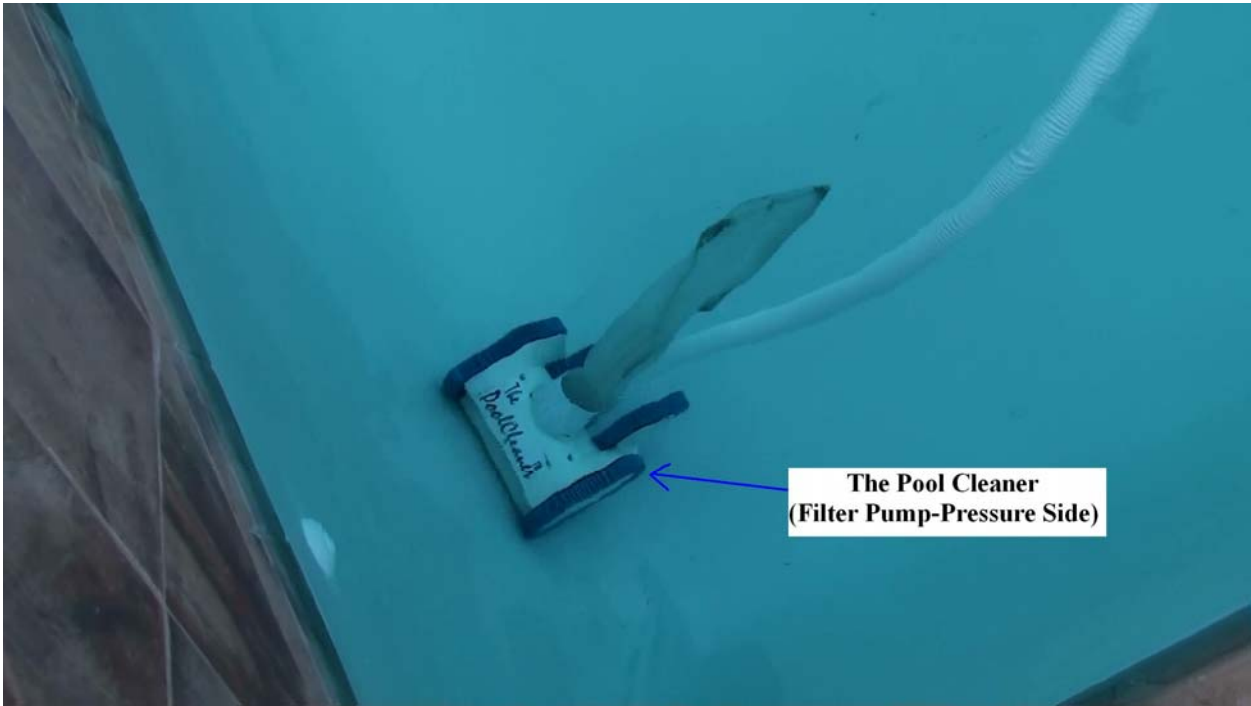

**Appendix: Figure L- Filtration Pump Pressure Side Cleaner-Pentair Letro**



**Appendix: Figure M- Filtration Pump Suction Side Cleaner-Polaris ATV**



**Appendix: Figure N- Filtration Pump Suction Side Cleaner-Zodiac G3-Baracuda**

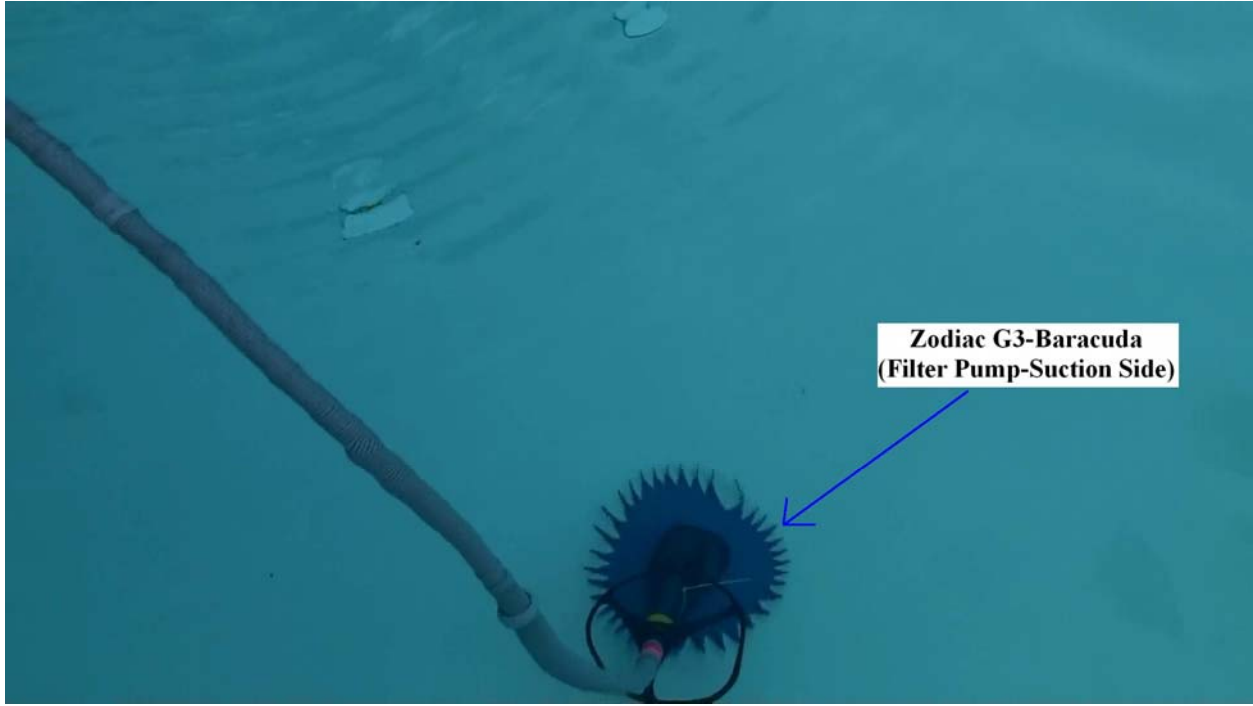

**Appendix: Figure O- Filtration Pump Suction Side Cleaner-Deep Sweep**

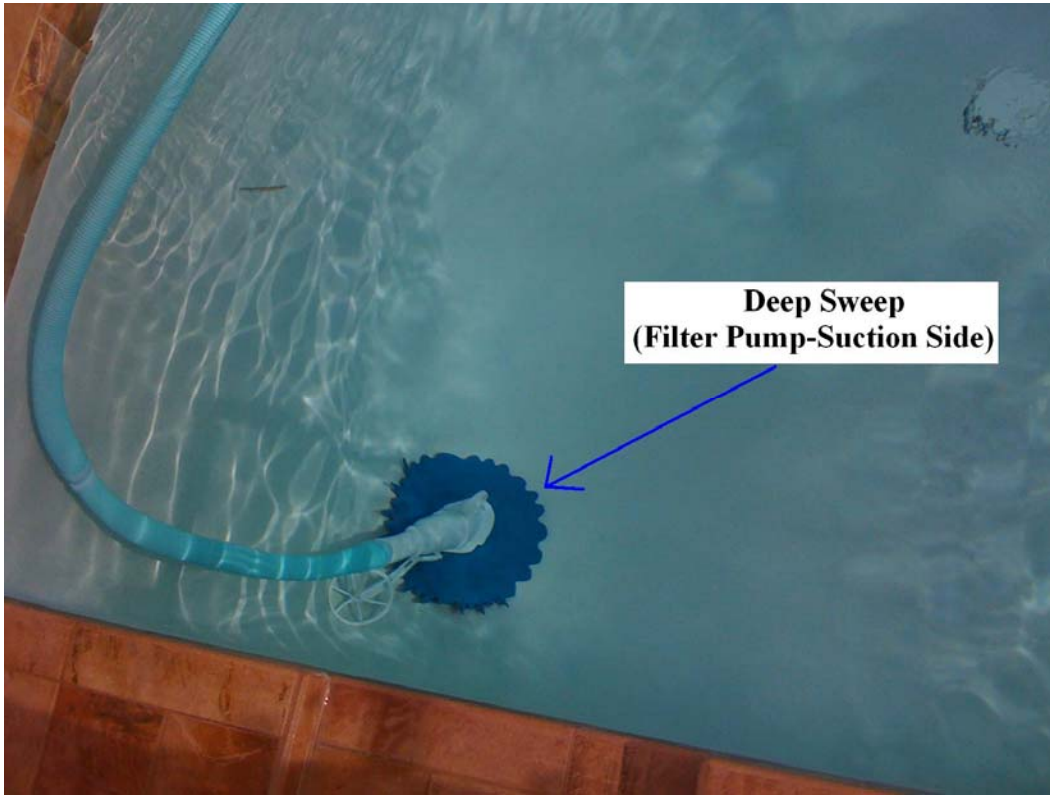

**Appendix: Figure P- Filtration Pump Suction Side Cleaner-The Pool Cleaner (No Test Picture)**

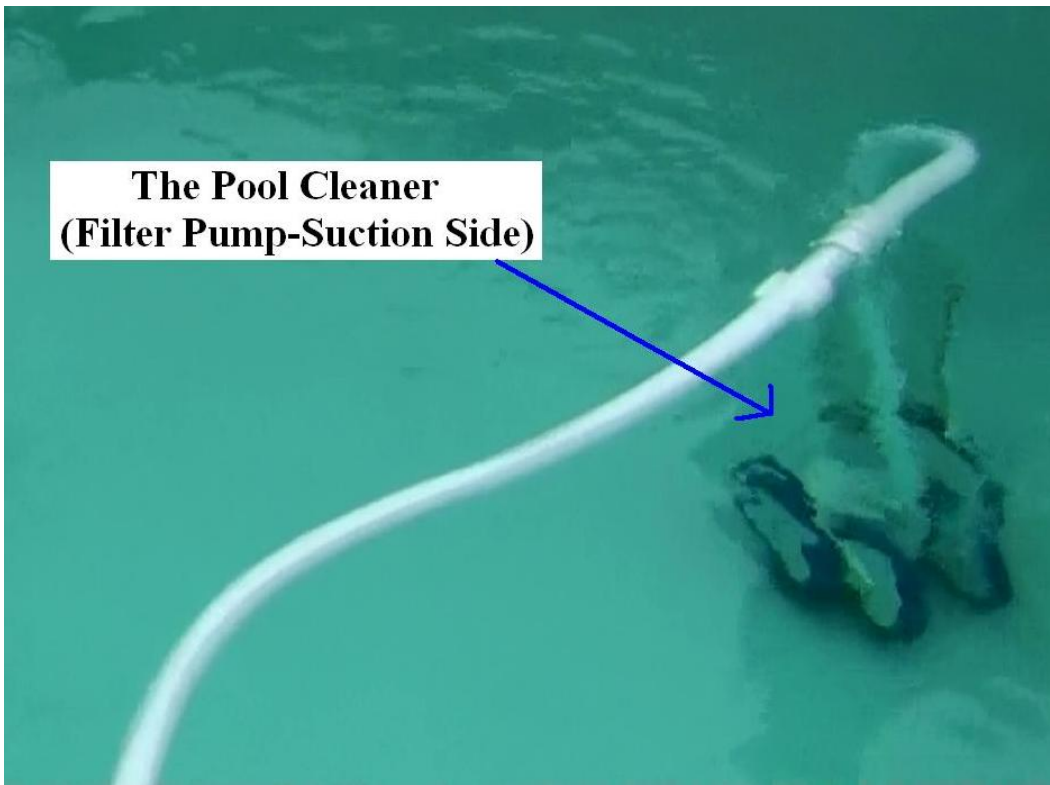

**Appendix: Figure Q- Filtration Pump Suction Side Cleaner-Hayward King Ray**





**Appendix: Figure R- Filtration Pump Suction Side Cleaner-Hayward Pool VAC Ultra**



## APPENDIX B: GRAPHS OF CLEANER FLOW VS CLEANER PRESSURE AND HYDRAULIC POWER

**Appendix: Figure S- Polaris 280 (Booster Pump Required)-Hydraulic Performance**

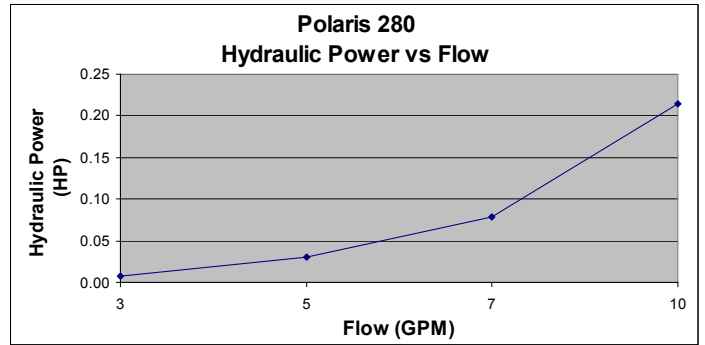
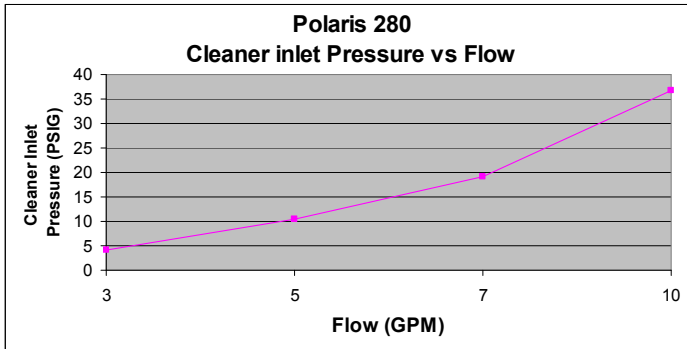

**Appendix: Figure T- Polaris 3900 Sport (Booster Pump Required)-Hydraulic Performance**

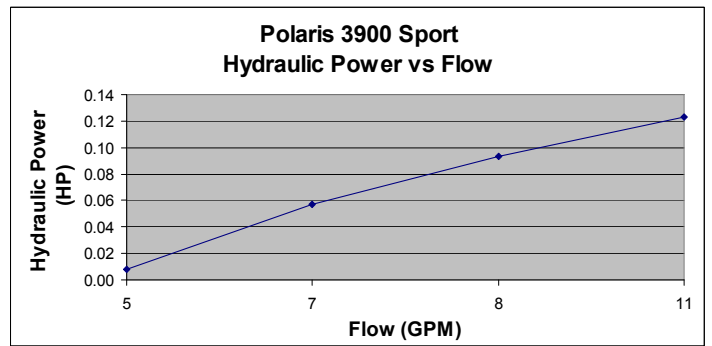
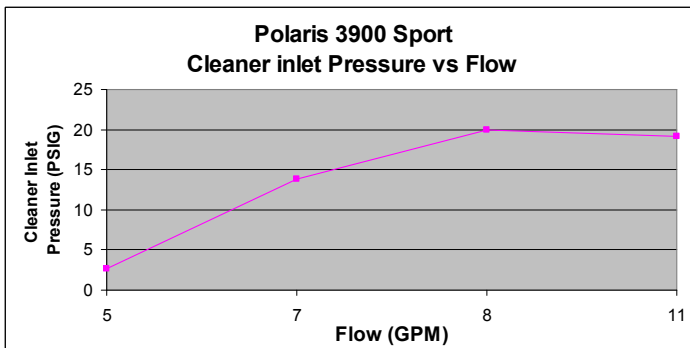

**Appendix: Figure U- Hayward Phantom (Booster Pump Required)-Hydraulic Performance**

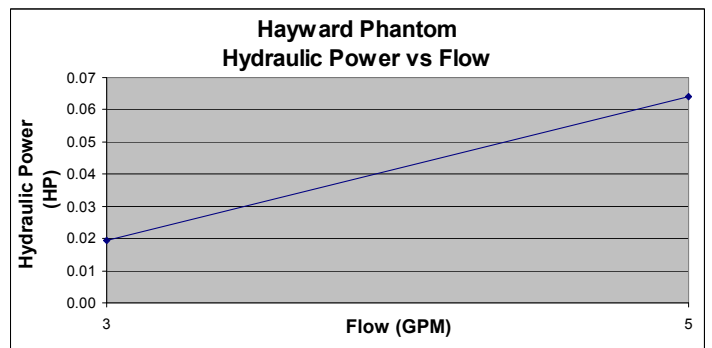
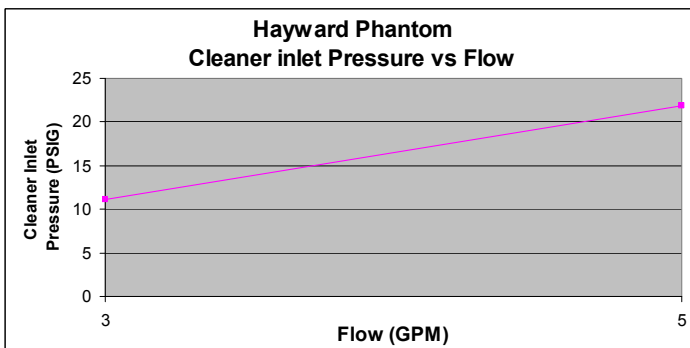

**Appendix: Figure V- Polaris 360 (Filtration Pump-Pressure Side)-Hydraulic Performance**

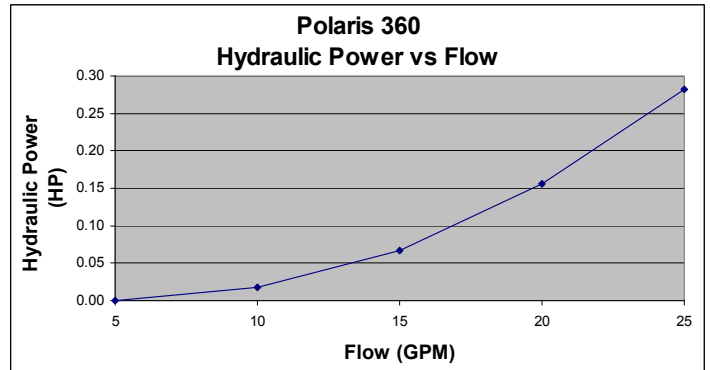
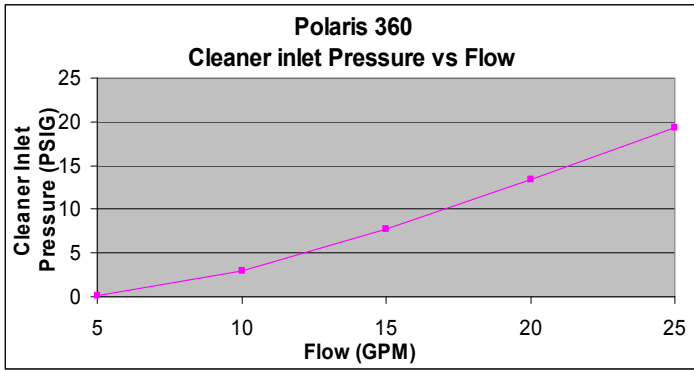

**Appendix: Figure W- The Pool Cleaner (Filtration Pump-Pressure Side)-Hydraulic Performance**

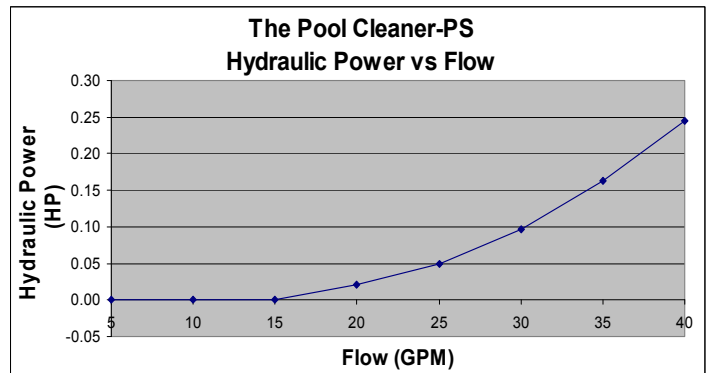
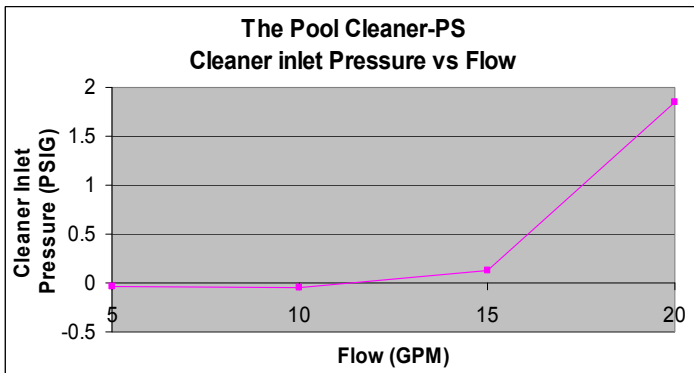

**Appendix: Figure X- Pentair Letro (Filtration Pump-Pressure Side)-Hydraulic Performance**

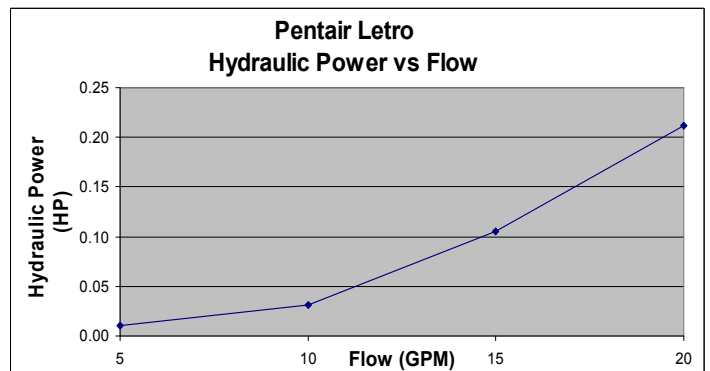
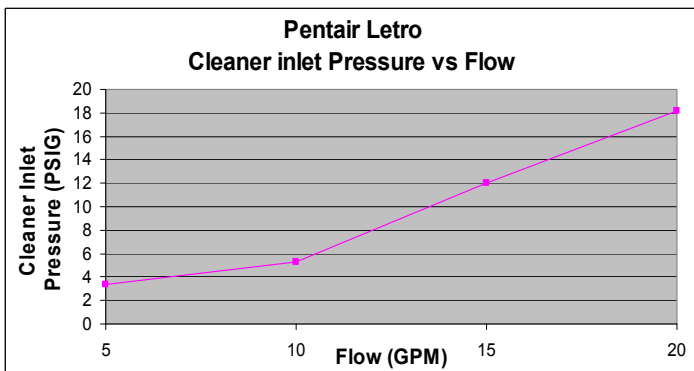

**Appendix: Figure Y- Polaris ATV(Filtration Pump-Suction Side)-Hydraulic Performance**

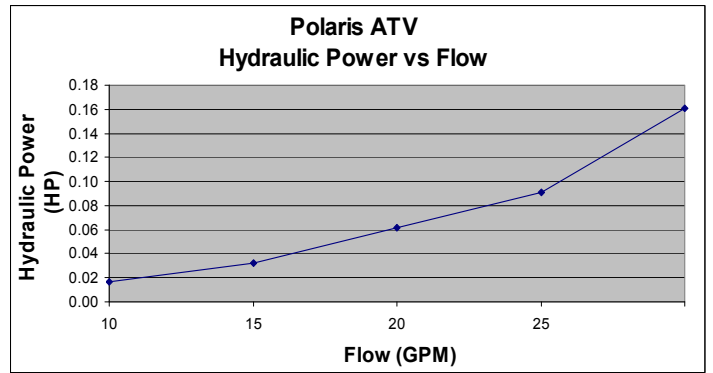
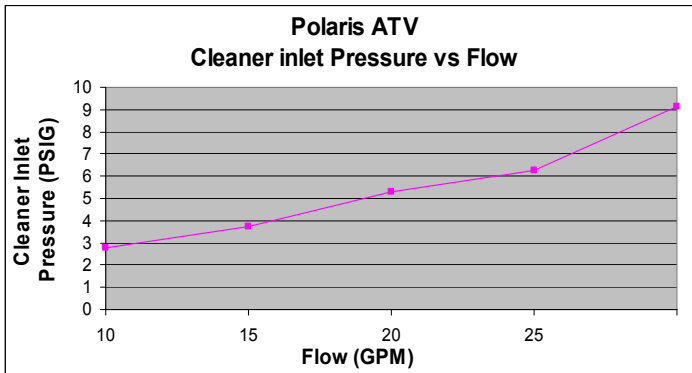

**Appendix: Figure Z- Zodiac G3 Baracuda (Filtration Pump-Suction Side)-Hydraulic Performance**

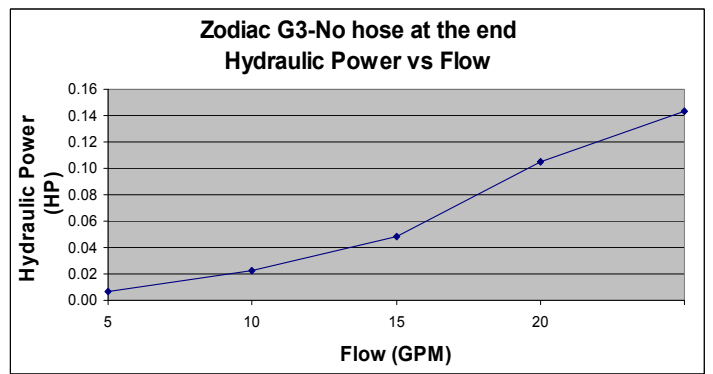
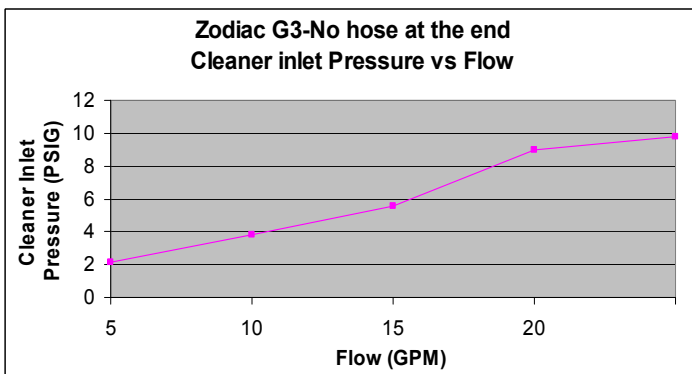

**Appendix: Figure AA- Hayward Pool Vac Ultra (Filtration Pump-Suction Side)-Hydraulic Performance**

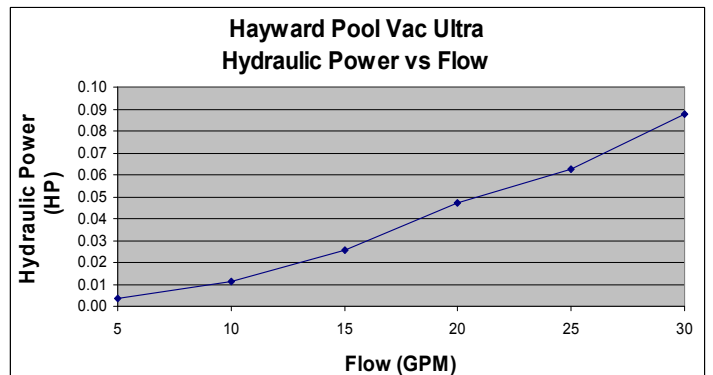
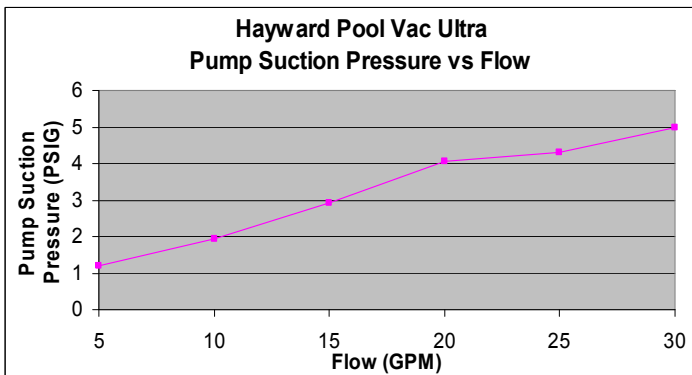

**Appendix: Figure BB- Hayward King Ray (Filtration Pump-Suction Side)-Hydraulic Performance**

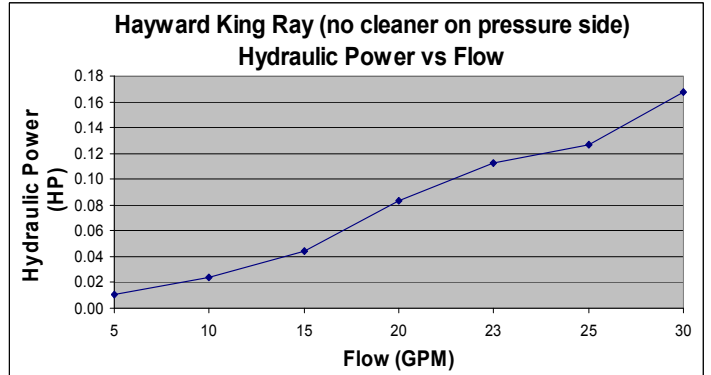
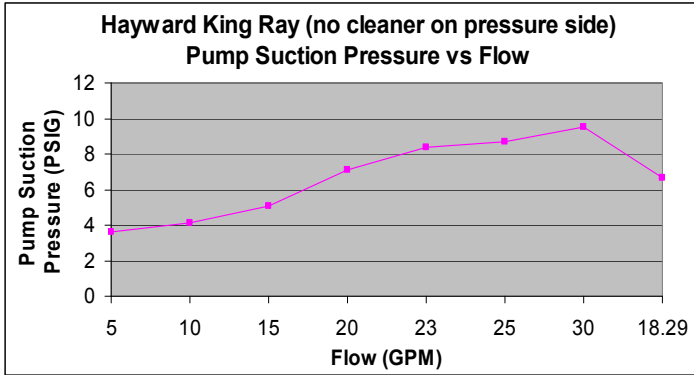

**Appendix: Figure CC- The Pool Cleaner (Filtration Pump-Suction Side)-Hydraulic Performance**

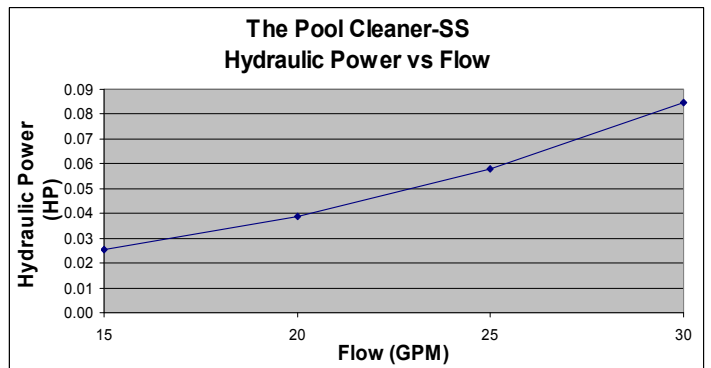
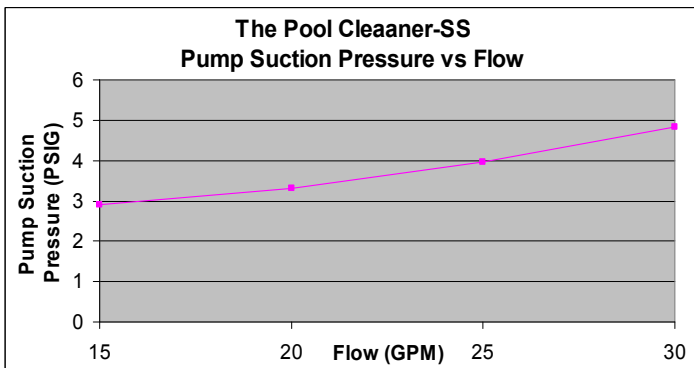

**Appendix: Figure DD- The Deep Sweep (Filtration Pump-Suction Side)-Hydraulic Performance**

